

## 125SV SERIES DIMENSIONS AND WEIGHTS AT 50 Hz, 2 POLES

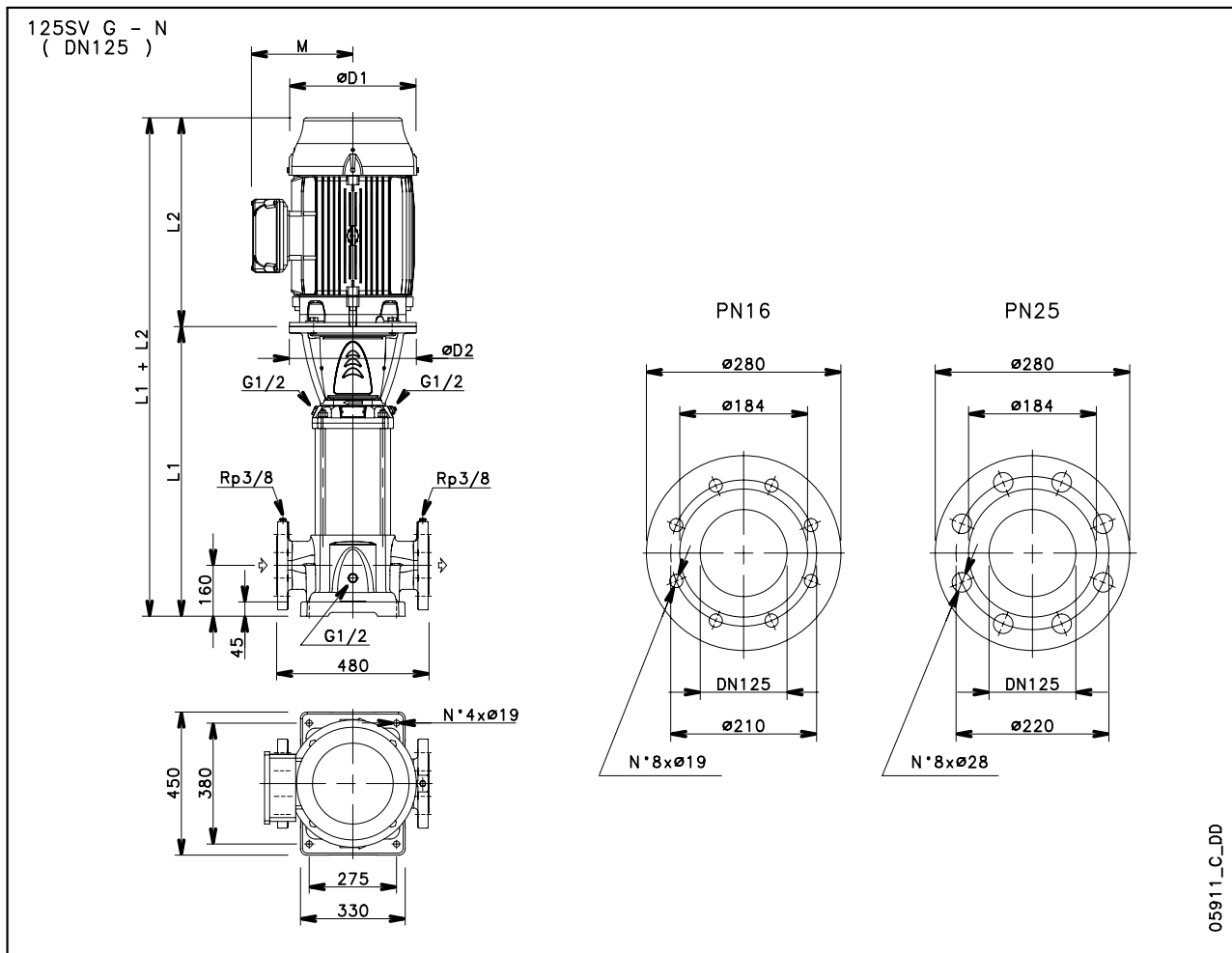

PUMP TYPE	MOTOR		DIMENSIONS (mm)						WEIGHT kg	
	kW	SIZE	L1	L2	D1	D2	M	PN	PUMP	ELECTRIC PUMP
125SV1../D	7,5	132	693	367	256	300	191	16	116	172
125SV2../D	15	160	878	494	313	350	240	16	131	233
125SV3../D	22	180	1028	494	313	350	240	16	143	265
125SV4../D	30	200	1178	657	402	400	317	16	161	376
125SV5../D	37	200	1328	657	402	400	317	16	172	402
125SV6../D	45	225	1478	746	455	450	384	16	187	543
125SV7../D	55	250	1658	825	486	550	402	25	216	666
125SV8/2A../D	55	250	1808	825	486	550	402	25	229	679

125sv-2p50-en\_c\_td

### 125SV SERIES OPERATING CHARACTERISTICS AT 50 Hz, 2 POLES

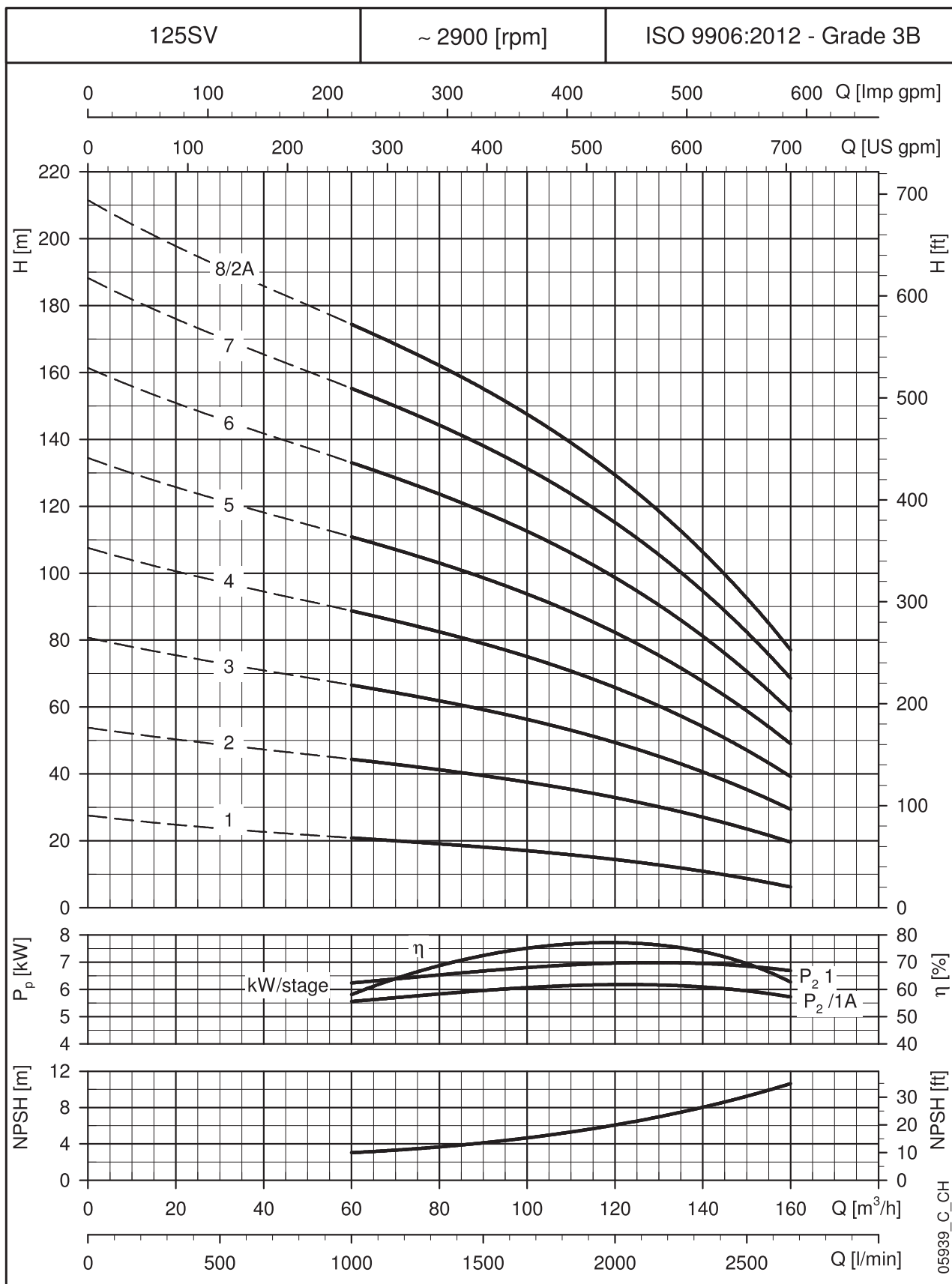

These performances are valid for liquids with density  $\rho = 1.0 \text{ Kg/dm}^3$  and kinematic viscosity  $\nu = 1 \text{ mm}^2/\text{sec}$ .